

Color CCTV Camera
WV-CP120

Operating Instructions



(Lens : option)

Panasonic®

Before attempting to connect or operate this product,
please read these instructions completely.

**CAUTION**RISK OF ELECTRIC SHOCK
DO NOT OPEN

CAUTION:
TO REDUCE THE RISK OF ELECTRIC SHOCK, DO NOT REMOVE COVER (OR BACK). NO USER SERVICEABLE PARTS INSIDE.
REFER SERVICING TO QUALIFIED SERVICE PERSONNEL.



SA 1965

The lightning flash with arrowhead symbol, within an equilateral triangle, is intended to alert the user to the presence of uninsulated "dangerous voltage" within the product's enclosure that may be of sufficient magnitude to constitute a risk of electric shock to persons.



SA 1966

The exclamation point within an equilateral triangle is intended to alert the user to the presence of important operating and maintenance (servicing) instructions in the literature accompanying the appliance.

For U.S.A.

Warning:

This equipment generates and uses radio frequency energy and if not installed and used properly, i.e., in strict accordance with the instruction manual, may cause harmful interference to radio communications. It has been tested and found to comply with the limits for a Class A computing device pursuant to Subpart J of Part 15 of FCC Rules, which are designed to provide reasonable protection against such interference when operated in a commercial environment.

The serial number of this product may be found on the top of the unit.

You should note the serial number of this unit in the space provided and retain this book as a permanent record of your purchase to aid identification in the event of theft.

Model No. _____

Serial No. _____

WARNING:

TO PREVENT FIRE OR ELECTRIC SHOCK HAZARD, DO NOT EXPOSE THIS APPLIANCE TO RAIN OR MOISTURE.

CONTENTS

PREFACE.....	2
FEATURES.....	2
PRECAUTIONS.....	3
MAJOR OPERATING CONTROLS AND THEIR FUNCTIONS.....	4
CAMERA SETUP.....	7
CONNECTIONS.....	8
LENSES.....	9
FOCUS ADJUSTMENT.....	15
INSTALLATION OF CAMERA.....	15
INSTALLING PROCEDURE.....	16
DIMENSION OF MOUNTING BRACKET.....	17
PREVENTION OF BLOOMING AND SMEAR.....	18
SPECIFICATIONS.....	19
STANDARD ACCESSORIES.....	20
OPTIONAL ACCESSORIES.....	20

PREFACE

The Panasonic WV-CP120 offers a new low end color camera through the use of a 1/3 inch interline transfer CCD image sensor

A single coaxial cable connects the camera and specified monitor or camera drive unit, and carries four signals audio, video DC power and vertical drive pulses. This simple system is specially designed for surveillance and security needs at offices, factories, schools, hospitals public or residential buildings, etc.

FEATURES

- Minimum illumination of 0.5 lx at F0.75 (equivalent 1.5 lx at F1.4) and signal-to-noise ratio of 46 dB by a 1/3 inch interline transfer CCD image sensor with 512 (H) X 492 (V) pixels
- Horizontal resolution of 330 lines
- Adjustable video level by auto light control (ALC) and electronic light control (ELC)
- Built-in automatic gain control (AGC +15dB) and automatic tracing white balance control (ATW)
- Backlight compensation (BLC) function for shooting objects when there is interference by background lighting
- Optional C-mount lens can be used together with the WV-AD20 optional lens mount converter

PRECAUTIONS

- **Do not attempt to disassemble the camera.**

To prevent electric shock, do not remove screws or cover. There are no user-serviceable parts inside.

Call a qualified service person for repairs.

- **Handle the camera with care.**

Do not abuse the camera. Avoid striking or shaking it. The camera could be damaged by improper handling or storage.

- **Do not expose the camera to rain or moisture, or try to operate it in wet areas.**

Do take immediate action if the camera becomes wet. Turn power off and call a qualified service person. Moisture can damage the camera and also cause electric shock.

- **Never direct the camera toward the sun.**

Whether the camera is in use or not, never direct it toward the sun. Do use caution when operating the camera in the vicinity of spotlights or other bright lights and light reflecting objects.

- **Do not operate the camera beyond its temperature or humidity range.**

Do not use the camera in an environment of high temperature or humidity. Use the camera under ambient conditions of -10°C - $+50^{\circ}\text{C}$ (14°F - 122°F) in temperature and 90% or less in humidity.

MAJOR OPERATING CONTROLS AND THEIR FUNCTIONS

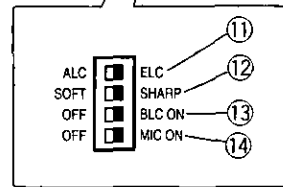
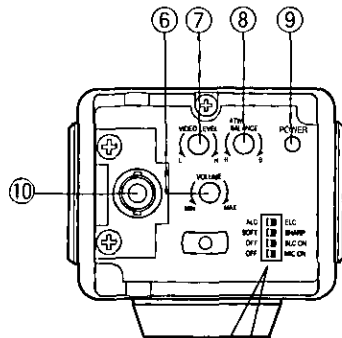
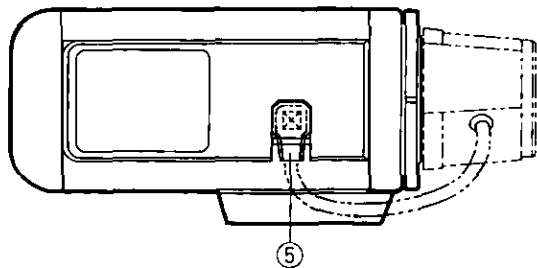
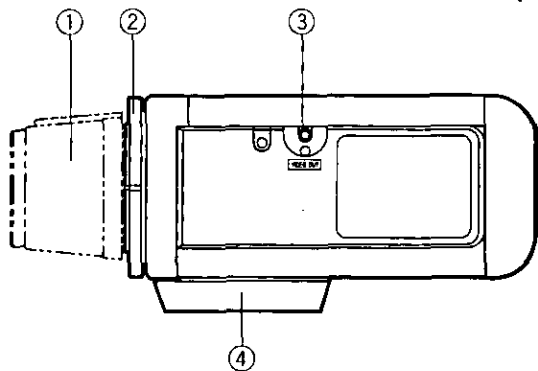

① **Lens (Option)**

See pages 9, 10, 11, 12 and 13 for details on lens selection. A standard C-mount lens can be used with the camera by adding the optional lens mount converter (C-mount adapter) WV-AD20.

② **Flange-back Adjusting Ring**

This ring is used to adjust the back focal length or picture focus by rotating it.

③ **Video Output jack (VIDEO OUT)**

This jack is used to adjust the angular field of view or focus while observing the picture on the monitor.

④ **Camera Mounting Screw Hole**

This screw hole (1/4" - 20) is used to mount the camera onto a mounting bracket or a tripod.

⑤ **Auto Iris Lens Connector**

This 4-pin connector supplies power and the DC control signal to the auto iris lens.

⑥ **Volume Control (VOLUME, MIN/MAX)**

The volume control is preset to center position at the factory. Adjust it to prevent howling.

⑦ **Video level Control (VIDEO LEVEL, L/H)**

This control adjusts the level of auto iris control when the ALC/ELC Switch⑩ is set to ALC position, or the level of electronic light control when the ALC/ELC switch is set to ELC position.

⑧ **ATW Balance Control (ATW BALANCE, R/B)**

This control adjusts the red and blue color balance. It is preset to center position which usually provides accurate color reproduction.

⑨ **Power Indicator**

⑩ **Camera Output Connector**

This connector is used to connect a coaxial cable to the CAMERA INPUT of the specified monitor or camera drive unit, to receive DC power and vertical drive pulse, and supply the audio and video output of the camera.

⑪ **ALC/ELC Switch (ALC/ELC)**

This switch is used to choose the lens as follows.

ALC: Choose this position when using an auto iris lens.

ELC: Choose this position when using a fixed or manual iris lens.

⑫ **Detail level Switch (SOFT/SHARP)**

The detail/aperture level can be chosen by this switch. Choose the desired position while observing the picture on the monitor.

Note: Usually choose SHARP position. When a Quad System is connected to this camera, set this switch to SOFT position.

⑬ **BLC ON/OFF Switch (BLC, ON/OFF)**

When backlight affects the picture, set this switch to ON position for a clearer picture.

⑭ **Microphone Switch (MIC, ON/OFF)**

Set this switch to ON or OFF as needed.

ELC (Electronic Light Control) Function

In this mode a continuously variable electronic shutter is employed to automatically control the exposure times in the CCD Image Sensor according to the incoming light level.

Cautions:

1. Under bright conditions such as outdoors, use an ALC type lens as the ELC control range is not wide enough under such conditions.
2. Under certain unique lighting conditions, the following may appear :
 - Strong smear and/or blooming on highlight objects such as spot lights or windows.
 - Noticeable flicker in the picture and/or color rendition variations.
 - Periodic variance of white balanceShould these phenomena occur, use an ALC lens.
3. When shooting in the ELC mode with a fixed iris lens, the depth of field of the image may be less than that obtained with an ALC lens. Depth of field varies inversely with the iris opening. Thus, using the camera in the ELC mode with the fixed iris lens fully opened will result in less depth of field than if an ALC lens were used. (In addition, distant objects in the picture might not be in focus.)

BLC (Backlight Compensation) Function

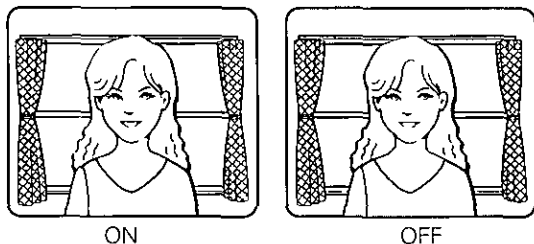

When strong, unwanted background lighting interferes with the clarity of important scene objects, turn this switch to 'ON' position

Cautions

- 1 Setting this switch to "BLC OFF" position is recommended when using the pan/tilt head or when the illumination of the object changes rapidly, since the Lens iris speed is slowed in "BLC ON" position
- 2 If the desired objects are not in the center of the picture, backlight compensation may not work effectively

CAMERA SETUP

Remove the rear cover fixing screw and pull the rear cover out as shown below

To improve performance, select the function switches located on the back

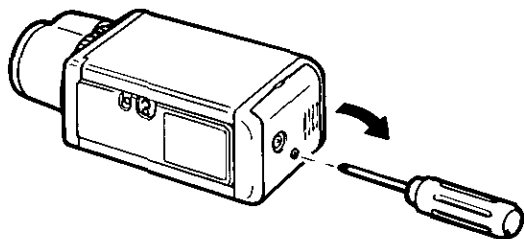

CONNECTION

Caution: Keep the POWER switch of the specified monitor, Camera Extension Unit and Camera Drive Unit in OFF position while making connections. If the power of these units is ON during connections, the camera does not function due to the built-in protection circuit which protects it against wrong connections.

• Basic System

Connect the coaxial cables between the camera and CAMERA IN connector of the specified monitor or Camera Drive Unit. The approximate maximum cable length is as follows:

Coaxial Cable Type	Maximum Cable Length	DC R/1000 ft. of Inner Conductor
RG-59/U	200 m (660 ft)	Less than 30 Ω
RG-6/U	500 m (1,650 ft)	Less than 12 Ω

The maximum DC resistance between the camera and these unit is 20 Ω .

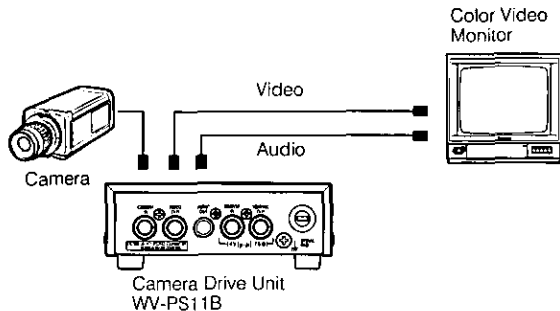
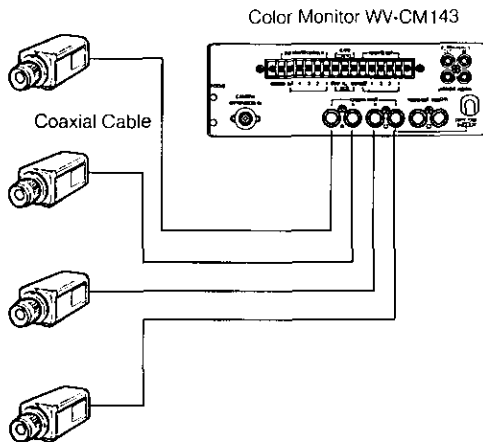

LENSES

1. Selection of Lens

<Auto Iris Lenses>

Models Specifications	WV-LA2.8 (Wide Angle)	WV-LA6A (Wide Angle)	WV-LA12A (Standard)	WV-LA18 (Telephoto)	WV-LA36 (Telephoto)	
Image Size	1/2" (6.4 (H) x 4.8 (V) mm)					
Focal Length	2.8 mm	6 mm	12 mm	18 mm	36 mm	
Maximum Aperture Ratio	1 : 1.4	1 : 1.4	1 : 1.4	1 : 1.4	1 : 1.8	
Angular Field of View 1/3"	H	87.5°	43.5°	22.2°	15.5°	7.7°
	V	69.2°	32.9°	16.7°	11.5°	5.7
Focusing Range	Adjusted by Camera			0.27 m - ∞ (0.89 ft - ∞)	1 m - ∞ (3.3 ft - ∞)	
Mount	CS-mount, 1"-32UN					
Filter Size	None	M37.5 mm, P = 0.5	M37.5 mm, P = 0.5	M37.5 mm, P = 0.5	M37.5 mm, P = 0.5	
Dimensions	ø43 x 32 mm (ø1-11/16" x 1-1/4")	ø53(W) x 43(H) x 41.5(D) mm [2-1/16"(W) x 1-11/16" (H) x 1-5/8"(D)]	53(W) x 43(H) x 41.5(D) mm [2-1/16"(W) x 1-11/16" (H) x 1-5/8"(D)]	ø43 x 41 mm (ø1-11/16" x 1-5/8")	ø43 x 41 mm (ø1-11/16" x 1-5/8")	
Weights	40g (0.09 lbs.)	45g (0.09 lbs.)	40g (0.09 lbs.)	70g (0.15 lbs.)	80g (0.18 lbs.)	

- Dimensions and weights indicated are approximate.
- Specifications are subject to change without notice.

<Auto Iris Lenses>

Models Specifications	WV-LZ81/6A (Motorized Zoom)	WV-LZ81/10 (Motorized Zoom)	WV-LA4R5C3A (Wide Angle)	WV-LA9C3A (Standard)	WV-LZ61/10 (Motorized Zoom)	
Image Size	1/2" (6.4 (H) x 4.8 (V) mm)		1/3" (4.8 (H) x 3.6 (V) mm)			
Focal Length	8.5 - 51 mm (6X)	8 - 80 mm (10X)	4.5 mm	9 mm	6 - 60 mm (10X)	
Maximum Aperture Ratio	1 : 1.2 (Wide) 1 : 1.3 (Tele)	1 : 1.4 (Wide) 1 : 1.7 (Tele)	1 : 1.2	1 : 1.2	1 : 1.6 (Wide) 1 : 2.6 (Tele)	
Angular Field of View 1/3"	H	Wide : 31.4° Tele : 5.5°	Wide : 33.5° Tele : 3.5°	56.4°	29.6°	Wide : 43.7° Tele : 4.6°
	V	Wide : 23.5° Tele : 4.1°	Wide : 25.2° Tele : 2.6°	43.3°	22.2°	Wide : 33.0° Tele : 3.5°
Focusing Range	1m - ∞ (3.3 ft - ∞)	1.1m - ∞ (3.6 ft - ∞)	Adjusted by Camera		1.2m - ∞ (4.0 ft - ∞)	
Mount	CS-mount, 1"-32UN					
Filter Size	M49 mm, P = 0.75	M55 mm, P = 0.75	None		M35.5 mm, P = 0.5	
Dimensions	86(W) x 62(H) 102(D) mm [3-3/8"(W) x 2-7/16"(H) x 4"(D)]	81(W) x 66(H) 117.5(D) mm [3-3/16"(W) x 2-5/8"(H) x 4-5/8"(D)]	ø43 x 38.5 mm (ø1-11/16" x 1-1/2")	ø43 x 38.5 mm (ø1-11/16" x 1-1/2")	71(W) x 52(H) 70.5(D) mm [2-13/16"(W) x 2-1/16" (H) x 2-3/4"(D)]	
Weights	420g (0.93 lbs.)	440g (0.97 lbs.)	42g (0.09 lbs.)	40g (0.09 lbs.)	210g (0.46 lbs.)	

- Dimensions and weights indicated are approximate.
- Specifications are subject to change without notice.

<Auto Iris Lenses>

Models Specifications		WV-LA4510 (Wide Angle)	WV-LA608 (Wide Angle)	WV-LA1208 (Standard)	WV-LZ83/6 (Motorized Zoom)
Image Size		1/2" (6.4 (H) x 4.8 (V) mm)			
Focal Length		4.5 mm	6 mm	12 mm	8.5 - 51 mm (6X)
Maximum Aperture		1:1.0	1:0.75	1:0.8	1:0.8 (Wide) 1:1.0 (Tele)
Angular Field of View 1/3	H	56.9°	43.8°	23.8°	Wide 31.3° Tele 5.5°
	V	43.6°	33.1°	17.6°	Wide 23.4° Tele 4.1°
Focusing Range		Adjusted by Camera			1.2 m - ∞ (4.0 ft - ∞)
Mount		CS-mount 1"-32UN			
Filter Size		None	M46 mm P = 0.75	M46 mm, P = 0.75	M67 mm, P = 0.75
Dimensions		54.5(W) x 43(H) x 43(D) mm [2-1/8 (W) x 1-11/16 (H) x 1-1/16"(D)]	64(W) x 52(H) x 55(D) mm [2-1/2"(W) x 2-1/16"(H) x 2-3/16"(D)]	73(W) x 66(H) x 72.5(D) mm [2-7/8 (W) x 2-5/8 (H) x 2-7/8"(D)]	90(W) x 77(H) x 123(D) mm [3-1/2(W) x 3 (H) x 4-13/16"(D)]
Weights		85g (0.19 lbs)	155g (0.34 lbs)	255g (0.56 lbs)	740g (1.63 lbs)

- **When using the above lenses with the camera, be sure to read the instruction manuals of the lenses**
- Dimensions and weights indicated are approximate
- Specifications are subject to change without notice

<Auto Iris Lenses>

Models Specifications	WV-LA210C3 (Wide Angle)	WV-LA408C3 (Wide Angle)	WV-LA908C3 (Standard)	WV-LZ62/2 (Variable focal)	
Image Size	1/3" (4.8 (H) x 3.6 (V) mm)				
Focal Length	2.1 mm	4.5 mm	9 mm	3.5 - 8 mm (2X)	
Maximum Aperture Ratio	1:1.0	1:0.75	1:0.75	1:1.4 (Wide) 1:2.0 (Tele)	
Angular Field of View 1/3"	H	107.6°	57.2°	31.3°	Wide 75.3° Tele 35.1°
	V	88.0°	43.7°	23.5°	Wide 57.0° Tele 26.4°
Focusing Range	Adjusted by Camera			0.3m - ∞ (0.92 ft - ∞)	
Mount	CS-mount, 1"-32UN				
Filter Size	None	M40.5 mm P = 0.5	M40.5 mm, P = 0.5	None	
Dimensions	62.5(W) x 52(H) x 41(D) mm [2-7/16 (W) x 2-1/16 (H) x 1-5/8 (D)]	62.5(W) x 52(H) x 57.5(D) mm [2-7/16" (W) x 2 1/16" (H) x 2-1/4 (D)]	62.5(W) x 52(H) x 57.5(D) mm [2-7/16" (W) x 2-1/16" (H) x 2-1/4 (D)]	56(W) x 52(H) x 64(D) mm [2-3/16 (W) x 2-1/16 (H) x 2-1/2 (D)]	
Weights	110g (0.24 lbs)	140g (0.31 lbs)	135g (0.30 lbs)	110g (0.24 lbs)	

- **When using the above lenses with the camera, be sure to read the instruction manuals of the lenses**
- Dimensions and weights indicated are approximate
- Specifications are subject to change without notice

<Manual and Fixed Iris Lenses>

Models Specifications	WV-LM4R5A (Wide Angle)	WV-LF6 (Wide Angle)	WV-LF12 (Standard)	WV-LF4R5C3A (Wide Angle)	WV-LF9C3A (Standard)
Image Size	1/2 (6.4 (H) x 4.8 (V) mm)			1/3 (4.8 (H) x 3.6 (V) mm)	
Focal Length	4.5 mm	6 mm	12 mm	4.5 mm	9 mm
Maximum Aperture Ratio	1:1.4	1:1.4	1:1.4	1:1.2	1:1.2
Angular Field of View 1/3"	H	56.9°	43.5°	22.2°	56.4°
	V	43.6°	32.9°	16.7°	43.3°
Iris	Manual	Fixed	Fixed	Fixed	Fixed
Focusing Range	Adjusted by Camera				
Mount	CS-mount, 1"-32UN				
Filter Size	M37.5 mm P = 0.5	M34 mm P = 0.5	M34 mm P = 0.5	M30.5 mm, P = 0.5	M30.5 mm, P = 0.5
Dimensions	ø44 x 41 mm (ø1-3/4" x 1-5/8")	ø38 x 41 mm (ø1-1/2" x 1-5/8")	ø38 x 41 mm (ø1-1/2" x 1-5/8")	ø34.4 x 36 mm (ø1-3/8" x 1-7/16")	ø34.4 x 36 mm (ø1-3/8" x 1-7/16")
Weights	93g (0.20 lbs)	38g (0.08 lbs)	33g (0.07 lbs)	29g (0.06 lbs)	23g (0.05 lbs)

- Dimensions and weights indicated are approximate
- Specifications are subject to change without notice

For lenses other than those listed on pages 9, 10, 11, 12 and 13, use a C-mount or CS-mount and make sure that the lens weight is less than 450g (0.99 lbs). If not, both the lens and camera should be secured. The protrusion of the rear of the lens should be as shown below.

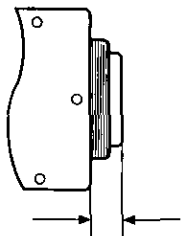

C mount Less than 11.5 mm (7/16")
CS mount Less than 7.2 mm (1/4")

Caution To use the C-mount lens, attach the Lens Mount Converter (C-mount adapter) WV-AD20 to the camera.

2 Mounting the Lens

Caution

Always turn the Flange-back Adjusting Ring clockwise by loosening the screws on the ring before mounting the lens. Otherwise the inner glass and CCD image sensor could be damaged by the lens.

- (1) Mount the lens by turning it clockwise onto the lens mount of the camera.
- (2) Connect the lens cable to the Auto Iris Lens Connector on the camera when the Auto Iris Lens is used.

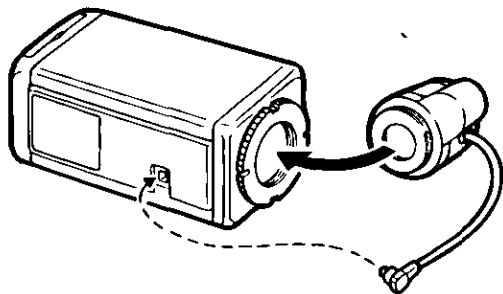

FOCUS ADJUSTMENT

1. Loosen the screws on the Focus Adjusting Ring.

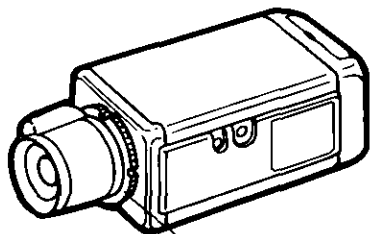

Flange-back Adjusting Ring

2. Turn the Focus Adjusting Ring to the desired position.

Caution: Do not turn this ring excessively counter-clockwise as this could damage the inner glass and CCD image sensor.

3. Tighten the screw on the Focus Adjusting Ring carefully (less than 0.5kg. cm of torque.)

INSTALLATION OF CAMERA

The mounting bracket can be fixed either on the top or bottom cover of the camera.

- **Mounting from the top**

Remove the mount adapter from the bottom of the camera as shown. The hole is for the standard photographic pan-head screw size (1/4" - 20).

Make sure that two original screws are used when mounting the mount adapter; longer type screws may damage the inner components.

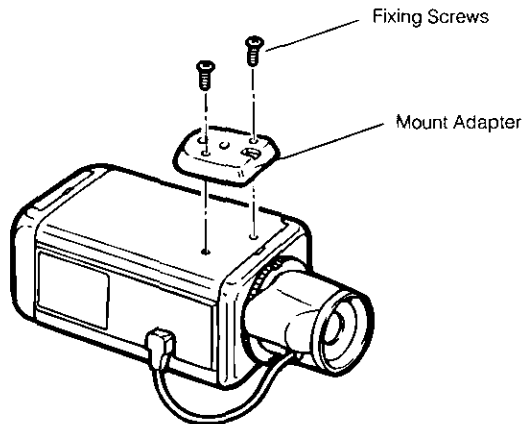

• Installation on the wall

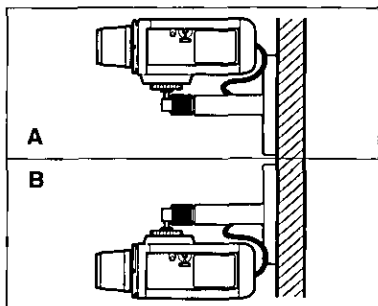

Fig. A, B

• Installation on the ceiling

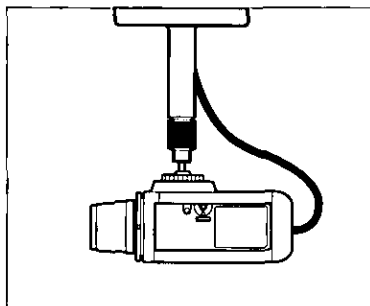

Fig. C

• Installation on a shelf or stand

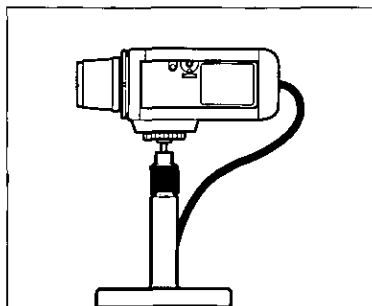

Fig. D

INSTALLING PROCEDURE

The explanation is for Fig. A, but applies equally to Figs. B, C and D.

1. Install the camera mounting bracket on the wall with 2 screws.

Note: The coaxial cable can be passed through the center hole of the camera mounting bracket.

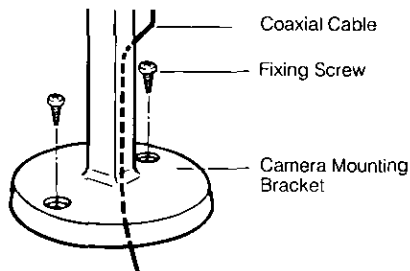

- 2 Insert the camera fixing screw into the camera mounting hole and tighten the screw firmly

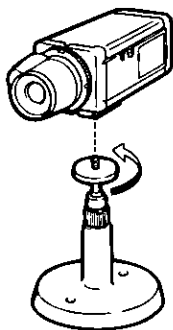

- 3 Connect the camera and monitor with the coaxial cable and turn on the power switch of the monitor
- 4 While viewing the monitor picture, loosen the angular control screw slightly. Adjust the camera's angle to the desired position, and then tighten the screw firmly

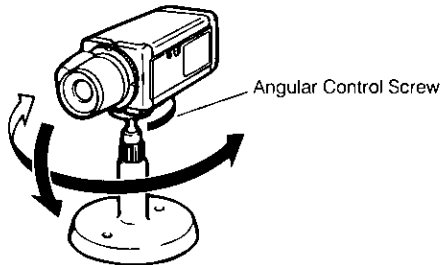

DIMENSIONS OF MOUNTING BRACKET

Unit mm (inch)

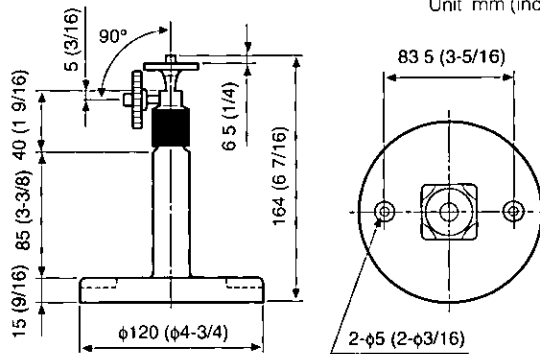

Cautions on installation

Use wood screws with the camera mounting bracket that are suitable for installation into a wood base of appropriate dimensions and strength. For installation in a material other than wood, refer servicing to qualified service personnel.

PREVENTION OF BLOOMING AND SMEAR

When the camera is faced toward spotlights or other bright lights and light reflecting objects, smear or blooming may appear. Therefore, the camera should be operated carefully in the vicinity of extremely bright objects to avoid smear or blooming.

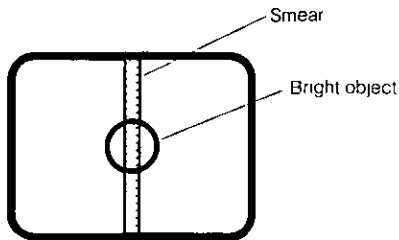

SPECIFICATIONS

Pick-up Device	Interline Transfer CCD, 512 (H) x 492 (V) pixels
Scanning Area	4.8 (H) x 3.6 (V) mm (equivalent to scanning area of 1/3" pick-up tube)
Synchronization	Multiplexed vertical drive (VD2) by use of specified camera drive unit
Scanning System	2:1 interlace
Scanning	525 lines/60 fields/30 frames
Horizontal	59.94 kHz
Vertical	15.734 Hz
Horizontal Resolution	330 lines
Video Output	1.0 V[p-p] composite, 75Ω/BNC connector
Signal-to-Noise Ratio	46 dB (AGC OFF, weight ON)
Electronic Light Control	Equivalent to continuous variable shutter speed between 1/60 s and 1/15,700 s
Minimum Illumination	0.5 lx (0.05 footcandle) at F0.75 [equivalent to 1.5 lx (0.15 footcandle) at F1.4 or 1.1 lx (0.11 footcandle) at F1.2]
Gain Control	Built-in AGC (+15 dB)
White Balance	ATW
Detail	Selectable SHARP or SOFT
BLC	Selectable ON or OFF
Audio	Selectable ON or OFF
Lens Mount	CS-mount
Ambient Operating Temperature	-10°C - +50°C (14°F - 122°F)
Ambient Operating Humidity	Less than 90%
Power Source	From the WV-PS11B/WV-PS104C

Dimensions (without lens)	71 (W) x 65 (H) x 125.5 (D) mm [2-13/16" (W) x 2-9/16" (H) x 4-15/16" (D)]
Weights (without lens)	440g (0.97 lbs)

Weights and dimensions indicated are approximate
Specifications are subject to change without notice

STANDARD ACCESSORIES

Body Cap	1 pc
Camera Mounting Bracket	1 pc

OPTIONAL ACCESSORIES

Lenses	WV-LA2 8, WV-LA6A, WV-LA12A, WV-LA18, WV-LA36, WV-LA4510, WV-LA608, WV-LA1208, WV-LA4R5C3A, WV-LA9C3A, WV-LA210C3, WV-LA408C3 WV-LA908C3, WV-LZ81/6A, WV-LZ81/10, WV-LZ83/6, WV-LZ61/10, WV-LZ62/2 WV-LM4R5A WV-LF6, WV-LF12, WV-LF4R5C3A, WV-LF9C3A
Lens Mount Converter (C-mount Adapter)	WV-AD20

Panasonic

Broadcast & Television Systems Company

Division of Matsushita Electric Corporation of America

IMAGING SYSTEMS DIVISION

Executive Office One Panasonic Way 3E 7, Secaucus New Jersey 07094

Regional Offices

Northeast 43 Hartz Way Secaucus NJ 07094 (201) 348 7303

Southeast 1225 Northbrook Parkway Suite 1 160 Suwanee GA 30174 (770) 338 6835

Midwest 1707 North Randall Road Elgin IL 60123 (847) 468 5200

Southwest 4500 Arnon Carter Blvd Fort Worth TX 76155 (817) 685 1117

Western 6550 Katella Ave 17A 5 Cypress CA 90630 (714) 373 7265

MATSUSHITA ELECTRIC OF CANADA LIMITED

5770 Ambler Drive Mississauga Ontario L4W 2T3 Canada (905)624 5010

PANASONIC SALES COMPANY

DIVISION OF MATSUSHITA ELECTRIC OF PUERTO RICO, INC

San Gabriel Industrial Park 65th Infantry Ave KM 9 5 Carolina Puerto Rico 00630 (809)750 4300